

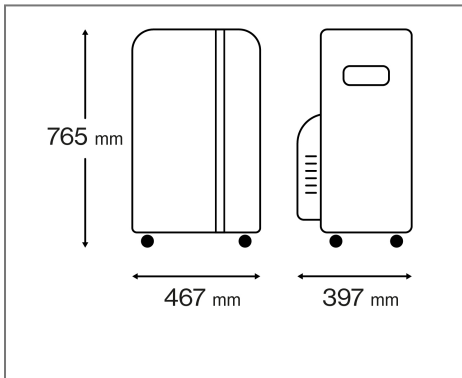

Model: **ACPO12W**

Description: Air Conditioner Portable 12000 BTU Wi-Fi 1350W



Product Features

- 3 in 1 Function: cooling, fan and dehumidifying with variable speed settings
- Compact and modern design to integrate with any decor
- Complete with 1.5m Long exhaust pipe
- Floor standing with omni-directional wheels for easy movement
- R290 - Refrigerant and auto frost protection function
- Wi-Fi Controlled via App

Technical Information

Wattage (W)	1450W
Accessories/Fixings Supplied	Ducting, Remote Control
Air Volume/Velocity (cbm)	300m ³
Antifrost Function	Y
Applications	Bedrooms, Offices, Living areas, Inside Use
Approvals/Certifications	CE, UKCA, RoHS
Body Material	HIPS
Cable Length (metres)	2.2m
Class	I
Compressor Brand	GMCC
Cooling Capacity (BTU)	12000BTU
Exhaust Outlet (Ø x mm)	Ø150 x 1500mm
Fan Position	Tilt
Frequency (Hz)	50Hz
Grill	HIPS
Hose Length (m)	1500mm
Humidity Removal Capacity (L/h)	3.45L/h
Ingress Protection (IP)	IPX0
Input Voltage (v)	220-240V
Mounting	Floor, Free Standing
Noise Level (dB)	55dB
Over-Heat Protection (Y/N)	N
Overcooling Protection	Y
Plug Type	13A 3 Pin Uk Plugtop
Product Colour/Finish	White
Rated Input Cooling	1350
Refrigerant	R290
Remote Control (Y/N)	Y
Remote Control/Wifi/Bluetooth	WIFI

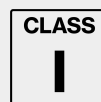



Screen Display	LCD
Suitable Room Size (m ²)	20m ²
Timer (Y/N)	Y
Warranty Period (Years)	1
Wifi/Bluetooth (Y/N)	Y
Dimensions (mm)	467*397*765mm
Barcode	5027825979101

