

BELIZE Digital radiator with Wi-Fi / Radiador digital con Wi-Fi /
Radiador digital com Wi-Fi / Digitale radiator met Wi-Fi

- EN** **INSTALLATION AND USER MANUAL**
Page 03
- ES** **MANUAL DE INSTALACIÓN Y USO**
Página 26
- PT** **MANUAL DE INSTALAÇÃO E DE UTILIZAÇÃO**
Página 48
- NL** **INSTALLATIE- EN GEBRUIKERSHANDLEIDING**
Page 70

**GUARANTEE / GARANTÍA
/ GARANTÍA / GARANTIE**

10

YEARS / AÑOS
/ ANOS / JAAR

3

YEARS / AÑOS
/ ANOS / JAAR

ON THE BODY
EN EL CUERPO
NO CORPO
IN HET LICHAAM

ON ELECTRONICS
EN ELECTRÓNICA
NA ELECTRÓNICA
IN ELEKTRONICA



SYMBOLS



DANGER. This symbol indicates a medium-high risk hazard which can result in serious injury or even death.



DO NOT COVER. Do not dry or leave clothes or towels on the radiator. Do not leave or place magazines, spray cans, volatile substances, or similar objects within 250 mm of the radiator.



HOT SURFACE. This symbol indicates that your surfaces are hot during and immediately after use. These must not be touched: danger of burns.



OBSERVE THE INSTRUCTIONS IN THE MANUAL. Please read this manual carefully before installing and using the product. Keep it for later use. Read all instructions and safety warnings. Failure to follow these can result in electric shock, fire or serious injuries.

INDEX

1. General Warnings	5
2. Technical information	8
3. Installation	9
4. Screen & Keypad	12
5. Functionality and programming	13
5.1. ON & OFF	13
5.2. Select the temperature	13
5.3. Temperature control	14
5.4. Lock / unlock button pad	14
5.5. Settings menu	14
5.5.1. Settings submenu	15
5.5.2. Energy submenu	16
5.5.3. Wi-Fi submenu	17
5.5.4. Prog. mode	18
6. Wi-Fi pairing	22
7. Maintenance and cleaning	22
8. European Regulation (WEEE) 2012/19/EU	22
9. Guarantee	23
10. How to register your product guarantee	25
Directive ERP Commission Regulation	92
Declaration of conformity	93

1. GENERAL WARNINGS

WARNINGS

This product may be used by children over 8 years of age and by persons with reduced physical, sensory, or mental capabilities, or lack of experience and knowledge under strict supervision or instruction in the safe use of the product and if they understand the hazards involved. Children should not plug, adjust, clean, play with, or perform maintenance on this product. Children under 3 years of age should be kept away from this product unless supervised.

DO NOT use the product in enclosed spaces if the persons present cannot leave the room independently and are not under constant supervision.



DO NOT COVER. To avoid overheating, do not cover the radiator.

DO NOT place spray cans, volatile substances, or similar objects within 250mm of the product.

DO NOT use insecticides, paints, or chemicals on or near the product.



Some parts of this product could reach high temperatures and cause burns. DO NOT touch the external parts of the product when in operation.

DO NOT install near curtains or other flammable materials.

Particular attention should be paid when children and vulnerable people are present.

When using electrical appliances, precautions should be taken to reduce the risk of fire, electric shock and injury.
Never insert fingers, body parts or objects inside the product.

Make sure that the voltage indicated on the product's technical information corresponds to the voltage output you have at your socket.

Any repair or maintenance that requires the product to be opened the product must be carried out by personnel authorised by ROINTE, who must also be notified if a leak is observed. Only official spare parts approved by ROINTE should be used. Please observe the current and relevant regulations when disposing of this product and its thermal fluid.

If the power cable is damaged, it must be replaced by personnel authorised by ROINTE to prevent any damage.

To avoid the risk of suffocation, do not leave the packaging including bags and other items within reach of babies or children.

The product has an IP24 degree of protection and can be used in bathrooms, but not in the vicinity of bathtubs, taps, showers, water connections, toilets, swimming pools or other masses of water. The product must never be installed where it, the switches or the control panel are within the reach of people in the water. Never use the product with wet hands. Do not place any water containers (glasses, vases, etc.) on or near the product.

IMPORTANT

- Disconnect the product from the power supply and make sure the product is at room temperature before any cleaning or maintenance. Do not use any abrasive substances on the product, such as (but not limited to) chemicals, coarse cloths, brushes, hard bristle, or wire/steel wool.
- To disconnect the product from the power source, remove the mains plug from the socket. Do not pull on the cable.
- ROINTE cannot be held responsible for incorrect sizing of the product unless it has been followed by an official ROINTE technical study.
- Before the first start-up, or before the start of winter, or when the product has not been used for many days, the appliance should be cleaned (follow the steps in the “maintenance” section of this manual).
- Do not sit or lean on the product.
- Temperature contrasts can generate “clicks” or noises in the device. This is not a fault of the product, but due to the expansion/contraction of the materials.
- When disposing of the product, the requirements set out in the legislation for the waste treatment and recycling must be followed. See WEEE in section 8.

2. TECHNICAL INFORMATION

MODEL	BRI0330RAD	BRI0550RAD	BRI0770RAD	BRI0990RAD	BRI1210RAD	BRI1430RAD	BRI1600RAD
Number of elements	3	5	7	9	11	13	15
DIMENSIONS, WEIGHTS & FINISHES							
Width (mm)	340	500	660	820	980	1,140	1,300
Height (mm)	575	575	575	575	575	575	575
Depth (mm)	95	95	95	95	95	95	95
Installed depth (mm)	118	118	118	118	118	118	118
Weight (kg)	8.0	12.0	16.0	20.0	24.0	28.0	32.0
Finish	White RAL 9010						
ELECTRICAL CHARACTERISTICS							
Nominal power (W)	330	550	770	990	1,210	1,430	1,600
Effective power (W)	132	220	308	396	484	572	640
Voltage (V)	230 ~V	230 ~V	230 ~V	230 ~V	230 ~V	230 ~V	230 ~V
Current (A)	1.4	2.3	3.3	4.3	5.2	6.2	6.9
SAFETY & INSTALLATION							
Safety thermostat	✓	✓	✓	✓	✓	✓	✓
Template & Installation Kit	✓	✓	✓	✓	✓	✓	✓
Grade of protection	IP 24	IP 24	IP 24	IP 24	IP 24	IP 24	IP 24
EAN Code	8435556138723	8435556138730	8435556138747	8435556138754	8435556138761	8435556138778	8435556138785

3. INSTALLATION

We recommend using a trusted Rointe supplier for installation of the product. Find the nearest one by calling us on **0203 321 5929** or using the locator on **www.rointe.co.uk**.

IMPORTANT: Prior to installation, please locate the metal tag located at the back of the product and note the product reference and serial number. You will need this information to register your guarantee. See section 10 for help on how to register the guarantee.

WARNING: Do not install the product directly over an electrical outlet or junction box. Do not install the product or use it outdoors. Do not install directly under a shelf. This product is designed to be installed on an interior wall using the ROINTE template, the installation kit and the fixings supplied. Do not install the product in such a way that it encounters the power cable.

The product must be mounted on the wall in the position shown in the accompanying image using the brackets and with the fixings supplied.

Our products transfer heat through the natural air convection. If the product is covered, this will disrupt the airflow and could cause overheating. It must be positioned in accordance with the minimum distances shown in the accompanying picture.

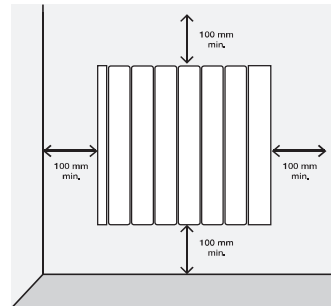

WARNING: The product has an IP24 degree of protection and can be used in bathrooms, but not in the vicinity of bathtubs, taps, showers, water connections, toilets, swimming pools or other masses of water. The product can only be installed in zone 3 of the accompanying picture. The product must never be installed where it, the switches or the control panel are within the reach of people in the water. Never use the product with wet hands. Do not place any water containers (glasses, vases, etc.) on or near the product.

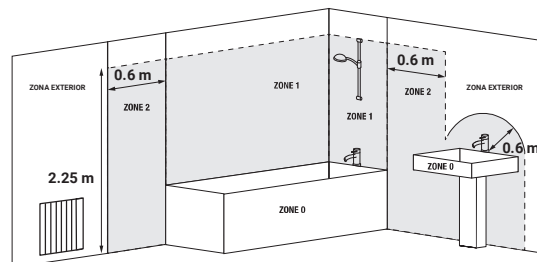

An installation kit is included in the product packaging. You will need a drill, a rubber mallet, a spirit level and a pencil to complete the installation.

WARNING: The weight of some of the products may be heavy. The installation may require two people.

IMPORTANT: Please follow these instructions carefully.

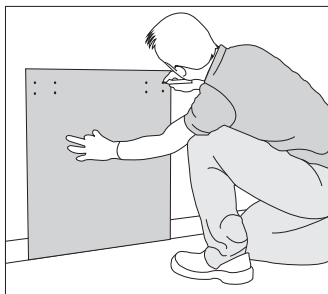

1. Remove the packaging and check that the installation contains brackets, screws, rawl plugs and a cardboard template.

2. Select a suitable location on the wall. Place the template on the wall and mark the holes for the brackets and screws. Observe the minimum distance requirements from the previous page.

Use the floor as a base for the template, not the skirting board.

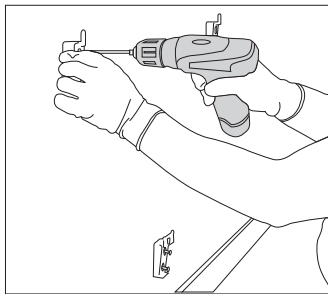

3. Remove the template and carefully drill out the marked holes.

4. Secure the upper brackets with the rawl plugs and screws provided. **To distinguish it, the lower bracket has a different design from the top ones.**

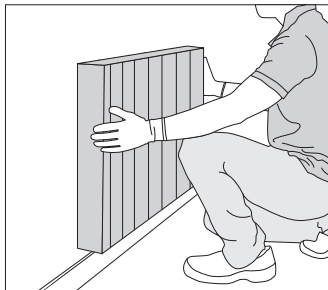
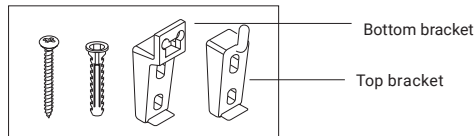

5. Slide the product up and down over the fixed brackets.

6. Check the straightness with a spirit level and adjust the supports accordingly if necessary.

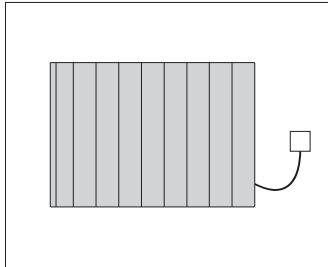

7. Connect your product to the power supply and switch it on.

8. See section 5 for operating instructions.

IMPORTANT: Template measurements per model

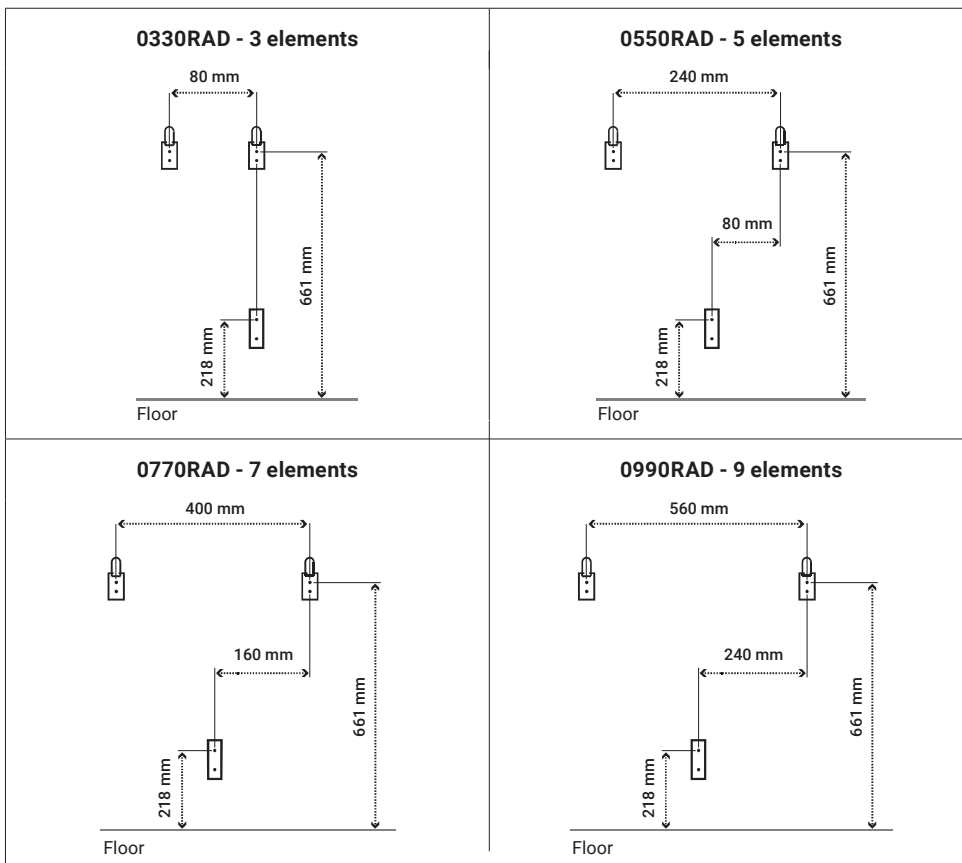

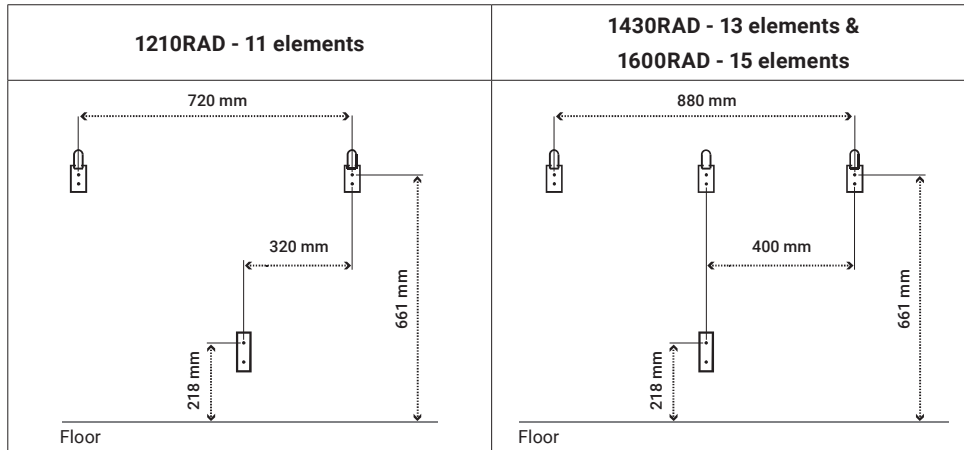

4. SCREEN & KEYPAD

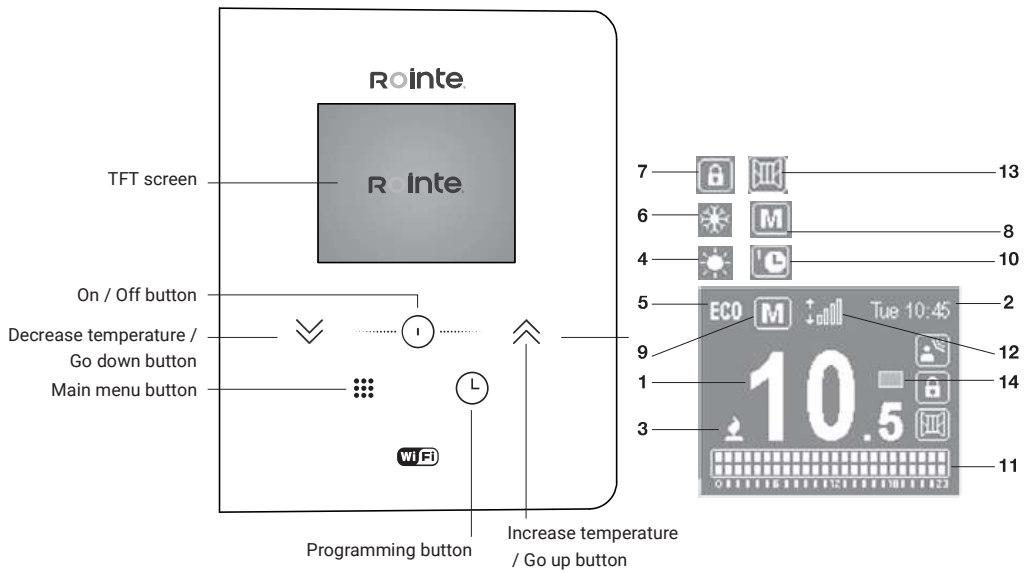

1	Selected temperature		8	Manual mode	
2	Current time and day		9	Automatic mode	
3	Heating element on		10	Preset programs mode	
4	Comfort mode		11	Hourly programming	
5	Eco mode		12	WiFi connection indicator	
6	Anti-Frost mode		13	Open Windows indicator	
7	Locked buttonpad		14	Energy consumption indicator	

5. FUNCTIONALITY & PROGRAMMING

5.1. ON & OFF

To turn the product on press the button once. To turn off press the button again. When you turn the product on for the first time, it will ask you to set the date and time. Use the buttons to select the correct time and press the button to confirm. Then use the buttons to select the correct minutes and press . Use the buttons again to select the correct day and press the button to confirm.

5.2. SELECT THE SET TEMPERATURE

You can regulate the set temperature of the radiator by using the buttons. Press the button to increase the product temperature by 0.5 °C or the button to decrease the temperature by 0.5 °C. The temperature ranges for each mode are as follows:



COMFORT	19 - 30 °C
ECO	7.5 – 18.5 °C
ANTI-FROST	7 °C

5.3. TEMPERATURE CONTROL

When the temperature in the room is lower than the selected one, the heating element is activated and the  symbol appears. The temperature control will perform an intelligently to activate and deactivate the electric current through the heating element to heat the fluid in the radiator.

5.4. LOCK / UNLOCK BUTTON PAD





The buttonpad can be locked using the control panel or the Rointe Lite App.

To lock / unlock the buttonpad using the product control panel, press and hold the  and  buttons together for 3 seconds.

The On/Off button will still work, even if the control panel is locked. Press the  button for 3 seconds to switch the product on or off.

5.5. SETTINGS MENU





Presione el botón  para acceder al menú de configuración. Las opciones disponibles son: Ajustes, Energía, Wi-Fi y modo de programación.

	Settings	Set time
		Backlight
		Language
		Firmware
		Energy
		Balance mode
		Adaptative mode
	Wi-Fi	On/off
		Link device
		Wifi info
	Prog. mode	On/off
		Preset programs
		User mode
		Pilot wire (only available on request)

Use the \swarrow \nearrow buttons to move between the menu options. A box will appear around the option you have selected. Press the \odot button to enter the submenu.



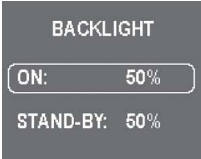

5.5.1. SETTINGS SUBMENU









Press the ☰ button to access the configuration menu. Then use the \swarrow \nearrow buttons to navigate to SETTINGS. Press the \odot button to access.





	<ul style="list-style-type: none"> • Set the day and time <p>To set the day or time select the CLOCK option.</p> <p>Use the \swarrow \nearrow buttons to select the correct time and press the \odot button to confirm. Then use the \swarrow \nearrow buttons to select the correct minutes and press the \odot button to confirm. Then use the \swarrow \nearrow buttons to select the correct day and press the \odot button to confirm.</p>	
	<ul style="list-style-type: none"> • Adjust brightness <p>This function allows you to adjust the brightness when the product is on or in standby.</p> <p>To adjust the brightness, select BACKLIGHT. With the \swarrow \nearrow buttons you can turn the brightness up or down. Press the \odot button to confirm.</p>	
	<ul style="list-style-type: none"> • Language <p>This function allows you to change the language of the product.</p> <p>To change the language, select LANGUAGE. Use the \swarrow \nearrow buttons to select the correct one and press \odot.</p>	

	<ul style="list-style-type: none"> • Firmware <p>Press the FIRMWARE option to see the current software version and the release date.</p>	<div style="background-color: #444; color: white; padding: 10px;"> <p>FIRMWARE</p> <p>VERSION: 0.1-1</p> <p>DATE: 01/01/2019</p> </div>
---	---	---





5.5.2. ENERGY SUBMENU





Press the  button to access the configuration menu. Then use the   buttons to navigate to ENERGY. Press the  button to access.







	<ul style="list-style-type: none"> • Open Windows <p>Use the   buttons to select whether you want this function On / Off and press  to save.</p> <p>See section 2 for more information on this function.</p> <p>When activated, the logo appears on the home screen, to the right of temperature, indicating that it is active.</p>	<div style="background-color: #444; color: white; padding: 10px;"> <p>OPEN WINDOWS</p> <div style="border: 1px solid white; border-radius: 5px; padding: 2px; display: inline-block; margin: 2px;">ON</div> <p>OFF</p> </div>
	<ul style="list-style-type: none"> • Balance <p>This function resets your product to a temperature of 19°C in Manual mode.</p> <p>Use the   buttons to select this option and press  to confirm. The screen will show 19°C in Manual mode.</p>	<div style="background-color: #444; color: white; padding: 10px;"> <p>OPEN WINDOWS</p> <div style="border: 1px solid white; border-radius: 5px; padding: 2px; display: inline-block; margin: 2px;">BALANCE MODE</div> <p>ADAPTATIVE MODE</p> <p>PRESENCE DETEC.</p> </div>

	<ul style="list-style-type: none"> • Adaptive mode <p>This function anticipates the product start-up, so that the room temperature at the start of the selected time is equal to the set temperature at the exact time that we have established during programming. This means your product will begin heating before the time set. This ensures the temperature is at the set temperature for the start of the time selected.</p> <p>To indicate that the algorithm is working, the icon will flash.</p> <p>Use the   buttons to select whether you want this function On / Off and press  to save.</p>	<div style="background-color: #333; color: white; padding: 5px; text-align: center;"> ADAPTATIVE MODE </div> <div style="background-color: #333; color: white; padding: 5px; text-align: center; margin: 2px;"> <input type="button" value="ON"/> </div> <div style="background-color: #333; color: white; padding: 5px; text-align: center; margin: 2px;"> <input type="button" value="OFF"/> </div>
---	---	--



5.5.3. WI-FI SUBMENU





Press the  button to access the configuration menu. Then use the   buttons to navigate to **WiFi**. Press the  button to access.

	<ul style="list-style-type: none"> • WiFi status <p>The WiFi STATUS option allows you to activate or deactivate the product WiFi module.</p> <p>Use the   buttons to select On / Off and press  to save.</p>	<div style="background-color: #333; color: white; padding: 5px; text-align: center;"> WiFi STATUS </div> <div style="background-color: #333; color: white; padding: 5px; text-align: center; margin: 2px;"> <input type="button" value="ON"/> </div> <div style="background-color: #333; color: white; padding: 5px; text-align: center; margin: 2px;"> <input type="button" value="OFF"/> </div>
---	--	--

	<ul style="list-style-type: none"> • Link device <p>The LINK DEVICE option generates a WiFi network to connect your product.</p> <p>When you select LINK DEVICE, the following screen will appear where you will be given the name of the network and the password.</p> <p>For more information on the pairing process, see section 6.</p> <p>Use the   buttons to select this option and press  to confirm.</p>	<div style="background-color: #333; color: white; padding: 5px; text-align: center;"> <p>NET: NTR80F2</p> <hr style="border: 0; border-top: 1px solid white; margin: 2px 0;"/> <p>PASSWORD: 02154867</p> </div>
	<ul style="list-style-type: none"> • WiFi info <p>The WiFi INFO option allows you to view information on the network status.</p> <p>When you select WiFi INFO, the following screen appears where you can see the IP, NM and GW.</p> <p>Use the  button to see more information.</p> <p>If you keep pressing the On/Off button, two more windows will appear: "Check Firmware Update" (YES/NO) and "Wi-Fi Status" (Enabled/Disabled).</p>	<div style="background-color: #333; color: white; padding: 5px; text-align: center;"> <p>WiFi STATUS</p> <p>dhcp: assigned</p> <p>IP, NM, GW:</p> <p>192.168.0.248 255.255.254.0 192.168.0.205</p> </div> <div style="background-color: #333; color: white; padding: 5px; text-align: center; margin-top: 10px;"> <p>WiFi STATUS</p> <p>MAC</p> <p>CC:50:E3 81:FE:C0</p> </div>

5.5.4. PROG. MODE

To change the status of your product from **MANUAL to AUTO** or vice versa, make a quick press of the  button. If you want to start programming your product, make a long press of the  button. To see all the options available for programming your radiator, select the option **PROG. MODE** in the main menu. The screen will show the following options:

	<ul style="list-style-type: none"> • Mode <p>From the MODE menu, select the operating mode you require: MANUAL or PROGRAMMING.</p> <p>Use the   buttons to select manual or programming and press  to confirm.</p>	<div style="background-color: #333; color: white; padding: 5px; text-align: center;"> <p>MODE</p> <div style="border: 1px solid white; border-radius: 5px; padding: 2px; display: inline-block; margin: 2px;"> <p>MANUAL</p> </div> <p>PROGRAMMING</p> </div>
---	--	--



- Preset heating programs**

From the **PRE-PROGRAMS** menu you can select a preset heating program to use. There are 4 available. Use ∇ \blacktriangle to select between the different programs and press \odot to confirm.

PRE-PROGRAMS

PRE-PROG 1

PRE-PROG 2

PRE-PROG 3

PRE-PROG 4

Available pre-programs













COMFORT ECO OFF











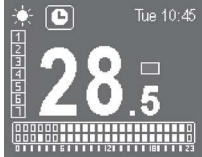

PRE-PROGRAM 1																								
	0	1	2	3	4	5	6	7	8	9	10	11	12	13	14	15	16	17	18	19	20	21	22	23
Mon-Fri																								
Sat-Sun																								

PRE-PROGRAM 2																								
	0	1	2	3	4	5	6	7	8	9	10	11	12	13	14	15	16	17	18	19	20	21	22	23
Mon-Fri																								
Sat-Sun																								

PRE-PROGRAM 3																								
	0	1	2	3	4	5	6	7	8	9	10	11	12	13	14	15	16	17	18	19	20	21	22	23
Mon-Sun																								

PRE-PROGRAM 4																								
	0	1	2	3	4	5	6	7	8	9	10	11	12	13	14	15	16	17	18	19	20	21	22	23
Mon-Fri																								
Sat-Sun																								

	<ul style="list-style-type: none"> • User program <p>This mode allows the user to make their own programming. There are 2 ways to start editing the programming:</p> <ol style="list-style-type: none"> 1. Do a long press on the  button. 2. Enter the submenu USER PROGRAM from the main menu. <p>Then follow the steps below.</p>	
	<p>STEP 1</p> <p>1. Select the COMFORT temperature: Temperature range 19 – 30 °C Use the   buttons to select the desired Comfort temperature. Press  to confirm.</p> <p>2. Select the ECO temperature: Temperature range: 7.5 – 18.5 °C Use the   buttons to select the desired Eco temperature. Press  to confirm.</p> <p>3. Select between ANTI-FROST or OFF: Temperature range: 7 °C / OFF Use the   buttons to select the ANTI-FROST or OFF. Press  to confirm.</p>	

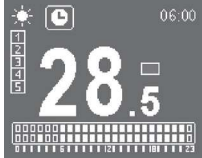
	<p>STEP 2</p>	<p>Select the days to be programmed</p> <p>Start on Day 1 (Monday).</p> <p>Press the  button to include this day in your programming. Press the  button again to exclude.</p> <p>Use the   buttons to move to the next day and repeat for all days of the week.</p> <p>The selected days will be highlighted by a box on the screen.</p> <p>Once you have reached Day 7, press the  button to advance to the next step.</p>	
	<p>STEP 3</p>	<p>Select the hour and mode to be programmed</p> <p>Start on 0h (midnight).</p> <p>Press the  button to select ECO, COMFORT or ANTI-FROST/OFF for that hour. Press  to move to the next hour and repeat.</p> <ul style="list-style-type: none"> • The upper right of the screen shows the hour you are programming. • The left side shows the selected days. • The bottom programming bar indicates: <ul style="list-style-type: none"> -Comfort mode: 2 shaded squares  -ECO mode: lower shaded square  -ANTI-FROST/OFF: 2 empty squares  <p>Once you reach 23:00 hours, press  to complete the programming.</p>	

	<ul style="list-style-type: none"> • Pilot wire <p>This option activates the pilot wire mode for those products that are connected to a control panel by means of a pilot wire.</p> <p>The product will be managed by the external pilot wire control unit to which it is connected.</p> <p>Use \checkmark \wedge to select this option and press \odot to confirm.</p>	<div data-bbox="1068 495 1269 655"> <p>FIL PILOT</p> <p>ON</p> <p>OFF</p> </div>
---	--	--

6. WI-FI PAIRING

To pair the device you must first create a zone in the application. Once inside this zone, press the icon \rightarrow to start the pairing wizard. If you need more information, you can consult the complete installation manual from the following QR code:



7. MAINTENANCE AND CLEANING

The product does not require any maintenance. We recommend cleaning the product (back, bottom of the product, etc.). Do not use abrasive substances on the product, clean it with a damp cloth and neutral pH soap and the screen with a dry cloth. Before carrying out any cleaning operation, make sure that the product is switched off and at room temperature.

8. EUROPEAN REGULATION (WEEE) 2012/19/EU

Based on the European regulation 2012/19/EU on Waste Electrical and Electronic Equipment (WEEE), these appliances cannot be thrown in the usual council bins; they must be collected selectively to optimise the recovery and recycling of the components and materials that make them up, and reduce the impact on human health and the environment. The crossed-out wheeled bin symbol on a horizontal bar is marked on all ROINTE products to remind the

consumer of the obligation to separate them for separate collection. The consumer should contact the local authority or the retailer for information regarding the correct disposal of their product.

9. GUARANTEE

1. Agreement

1.1. This section describes the guarantee conditions available to the buyer when purchasing a new product of the Rointe brand. These conditions include all the rights that the buyer has in accordance with current national legislation, as well as the guarantee and additional rights offered by the brand. Any incident detected in your Rointe product can be dealt with by the seller of the product or in a more agile way through the manufacturer itself.

1.2. Rointe offers you Technical Assistance from our After-Sales Service by telephone at +44 (0)203 321 5929 or email to support@rointe.co.uk, where we will indicate the steps to follow to solve the incident. You will need the product reference (located on the metal characteristics label), serial number, date of purchase and the nature of the fault when contacting us. In addition, you must have a copy of the proof of purchase of the product.

1.3. ROINTE guarantees there are no material defects of design or manufacture at the time of original purchase. ROINTE guarantees the body for 120 months (10 years) and the electrical plus electronic components for 36 months (3 years) for this product only, from the date of purchase, or delivery if later, provided it has not been modified, and in accordance with the provisions of the following stipulations.

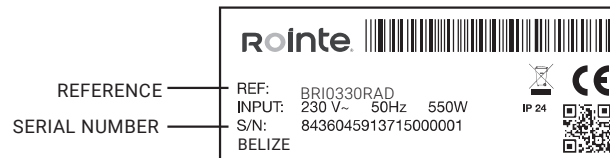

2. Conditions

2.1. If during the guarantee period, the product under normal use, and with proper maintenance, fails to function properly and is found to be defective in design, material, or workmanship, it will be repaired or replaced at the customer's option, in accordance with the provisions of the law, and subject to the following terms and conditions:

2.1.1. The guarantee is only applicable if the original guarantee is issued by the seller and when such guarantee has been registered with Rointe correctly, including the product reference, serial number (marked on the metal label of the product), date of purchase and proof of purchase. The product guarantee can be registered

on our website at www.rointe.co.uk or can be emailed to support@rointe.co.uk within 90 days of installation. ROINTE reserves the right to refuse a guarantee when this information has been removed or modified after the original product purchase.

2.1.2. The guarantee is only applicable if the product has been installed by a competent person in accordance with this installation manual and all regulations in force at the time of installation.

2.1.3. The guarantee is only applicable to those cases that refer to defects in material, design and manufacture, and in no case covers damage to the product for the following reasons:

- i) Damage caused by negligence and/or misuse of the product, i.e. used for purposes other than its normal use, or by not respecting the instructions for use, maintenance and cleaning given by ROINTE, as well as by incorrect or inadequate installation or use of the product that may not comply with the technical safety standards in force.
- ii) Corrosion of any part of the product caused by direct exposure to saltwater. Where the product is installed within 200 m of the coast, the guarantee period for damage caused by corrosion shall be reduced by 50%.
- iii) Any unauthorised modifications or repairs to the product carried out by third parties or unauthorised persons, or the opening of the product by third parties or unauthorised persons.
- iv) Any accident deemed to be beyond ROINTE's control, such as (but not limited to): lightning, fire, flood, natural disasters, public disorder, atmospheric or geological phenomena, and all those of a similar nature.
- v) Failures resulting from incorrect installation. In case of doubt, please contact ROINTE.

2.2. Any repair or replacement carried out as part of this guarantee service does not allow for extension periods or new guarantee periods, i.e. your guarantee will not be extended in the event that a repair or replacement of this product is carried out, but will be suspended until the product is returned repaired or a new one is delivered.

2.3. Any repair or replacement covered by this guarantee must be a functionally equivalent part. Defective parts or parts removed or replaced shall become the property of ROINTE and must be returned as such.

2.4. The product must be installed in such a way as to allow access by ROINTE technicians or authorised persons in the event that they need to access the product for repair or maintenance. The user/customer is responsible for the organisational means necessary to allow access to the products by ROINTE for repair or replacement.

2.5. ROINTE's Technical Support department will advise you if you need to purchase any parts not covered by this guarantee or outside of this guarantee.

2.6. This guarantee will not be valid if the product has been tampered with, modified and/or repaired in any way and/or by unauthorised persons. This guarantee will also not

be valid if the product is not correctly installed.

2.7. This guarantee is not transferable and does not include claims for limescale or frost damage.

2.8. This guarantee does not affect the purchaser's statutory rights under applicable national legislation, nor does it affect any rights contracted with the dealer or installer that may arise in performance of the contract of sale.

2.9. ROINTE, its offices, employees, distributors and installers shall not be liable for any incidental damages arising from the infringement of any rule implied in this product, as well as for its improper or incorrect use.

2.10. Check the EULA conditions (supplied with the product for Wi-Fi connected products) for information on the legal agreement you accept when installing a ROINTE product. For product or guarantee assistance, please contact ROINTE by telephone at +44 (0)203 321 5929 or by email to support@rointe.co.uk.

10. HOW TO REGISTER YOUR PRODUCT GUARANTEE

IMPORTANT: It is important that you register your ROINTE product as part of our guarantee service, in case you wish to make a claim.

You can register your ROINTE product in the following ways:

WEB

1. Go to <https://rointe.com/uk/register-your-guarantee/>
2. Log in to your existing account or create a new account if necessary.
3. Click on "My products".
4. Enter your product reference (alphanumeric and in capital letters).
5. Enter your serial number (26 digits located on the metal tag of your product starting with 84).
6. Upload your proof of purchase, such as your invoice in PDF, JPEG or PNG format. This is not mandatory, but doing so ensures that your warranty period is accurate.
7. Click on "Register".
8. Congratulations! Your product is now registered.

EMAIL

1. Send an email to support@rointe.com with the following information:
 - Customer name
 - Address and postcode
 - Telephone number and email address
 - Product reference
 - Serial number
 - The date of purchase of the product and proof of purchase (as described in the WEBSITE section above).
 - Our technical support team will confirm product registration and request any additional information needed by email.

POSTAL

1. Send the information listed in the EMAIL section to:
 - INDUSTRIAS ROYAL TERMIC, S.L. - Rointe, C/E Parcela 43, 30140, Santomera (ESPAÑA).
2. Please ensure you obtain proof of postage.